

Studies on Densification, Baling and Expansion Characteristics of Paddy Straw¹

S.D. Kulkarni¹ and S. Mangaraj²

ABSTRACT

A baling machine developed earlier in the Institute (CIAE) was used for the study. The U-Clip welding method of tying the bales required only 60 s as compared to over 280 s in conventional baling and found economical with a cost of only Rs 1.93/bale. Compressibility and the expansion characteristics of paddy straw at 10-30% moisture levels were studied. The rate of expansion during first 30 seconds was maximum and it decreased rapidly after 5 min.

Many parts of the country face deficit of feed and fodder for millions of livestock. Harvesting, transportation, chaffing, handling and conservation of forage crops and crop residues are very important practices and are needed for effective utilization of fodder. The critical period of forage growth is very short where the nutritive value and dry matter of the forage maximizes and any delay in its harvest results in substantial loss in terms of its feeding value (Gupta et al, 1997-98, Gupta 2000). High volume and low value of crop residues, grasses and fodder crops do not permit their economic transportation from surplus to deficit areas. The need for its transportation becomes very pressing during the Period of shortages due to droughts and floods. The study was undertaken to (i) make the operation of small capacity baler economical and (ii) study the expansion characteristics of paddy straw for deciding critical tying time / duration.

MATERIALS AND METHODS

The Baling Machine

The existing machine developed earlier in the Institute (CIAE) was used (Fig. 1). Data reported for the machine (Prakash & Gupta, 1986) was considered as a base for preliminary trials and study. Details of the machine are:

Machine specifications

Overall dimensions : 4000 mm x 800 mm x 200 mm

Power required : 3 hp. 3N 1440 rpm, electric motor

Compression ratio : 3:1 (by volume)

Bale Specifications

Size of bale : 520 mm x 450 mm x 450 mm

Initial density of straw : 65 kg/m³

Density of bale : Up to 200 kg/m³

Weight of bale : Up to 20 kg at 8% m.c.

¹Soybean Processing & Utilization Centre & ²Agro Processing Division respectively, Central Institute of Agricultural Engineering, Nabi Bagh, Bhopal – 462 038 @: Corresponding author (e-mail <sdk@ciae.mp.nic.in>)

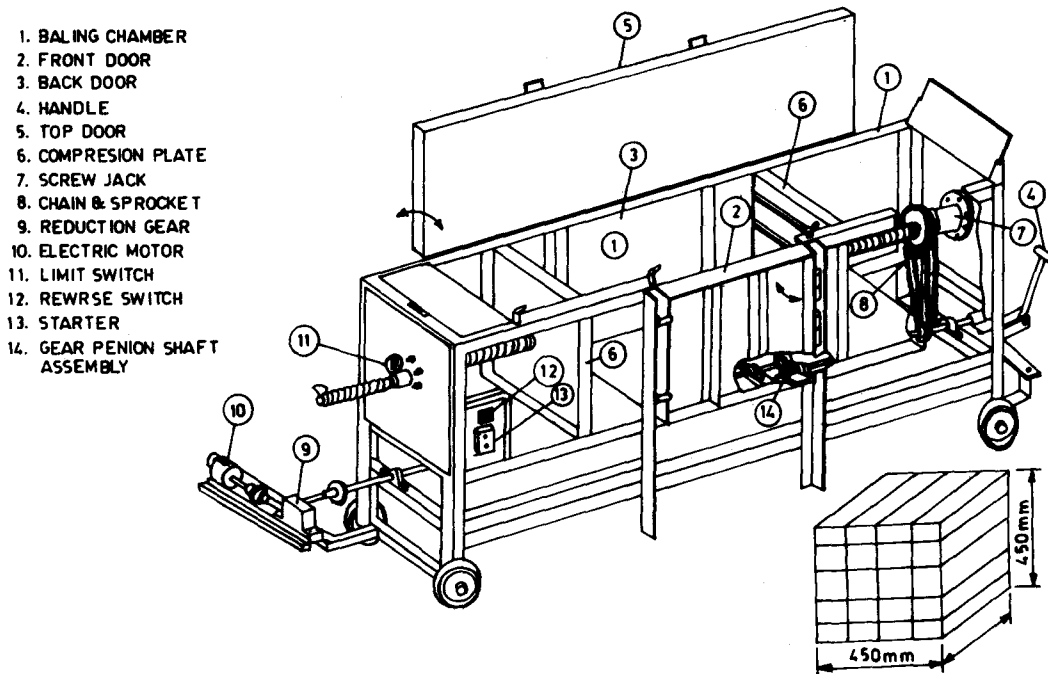

Fig. 1. CIAE baling machine

Compression ratio : 3:1

Time of baling/ bale : 10 - 12 minute

Experimentation

Paddy straw was used for the study. Details of experiments are presented in following sections:

Straw filling approach

Experiments were conducted with three straw filling approaches using the paddy straw. These included: 1) Free filling, 2) Filling with simultaneous mild pressing by hand, and 3) Filling with simultaneous pressing by foot to accommodate maximum possible straw. The durations for filling compression/densification, return stroke and tying of bale were recorded. At least two labourers were required for the operation of the machine. Hence it was

found necessary to modify the machine for unloading the bale with the help of supporting guards, which was provided for easy unloading. Further studies were carried out to reduce the time of tying.

Tying Methods

Different tying materials and approaches were attempted to reduce the cost and time of tying. Details are as follows:

Old Method of Tying

The method suggested by Prakash and Gupta (1986) was practiced as a control. After completion of the compression, the front and backside doors are opened. The rope was inserted through both sides of the compressed straw with the help of a long needle for ensuring the better grip. Grooves were made

on the bottom plate of the baler for easy movement of the rope. Three different types of tying materials tried were jute, nylon and mild steel binding wires.

Prefab Wire Mesh

To reduce time of tying, prefab wire mesh was tried. A wire mesh of 7.62X7.62mm (3x3 inch) opening and 13 gauge thickness was cut according to the required dimensions of the bale. The mesh was placed at predefined locations and the side wire mesh with different locking arrangement were made and tried (Fig.2).

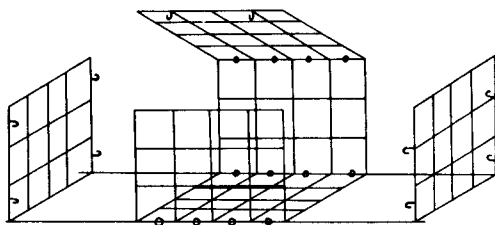

Fig. 2. Prefab wire mesh arrangement

U-Clip Welding Method

In this method, 4 U shaped pins were welded at 4 corners of both the compression plates. Then four bars of height equal to the height of the bale chamber were placed in the U clip. Thus the total 4 bars were placed between two compression plates. Then wire was wrapped through channels around the bar when the compression plates reached the position of complete compression (Fig. 3).

Expansion characteristics

A set of experiments was carried out with baling machine to study the expansion characteristics of compressed paddy straw at different moisture levels like 10%, 15%, 20%, 25%, 30%. The paddy straw was taken, filled

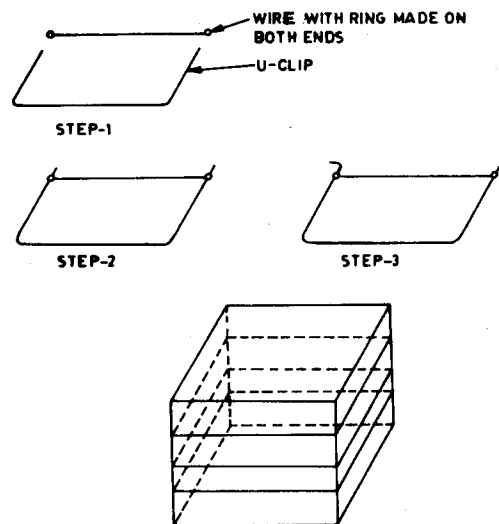

Fig. 3. U-clip system for tying of bale

in the baler and compressed for the experimental purpose. After compression, it was allowed to expand freely in three different directions separately (i.e. length, width and height). Then the expansion was noted down after 30 seconds, 1 min., 5 min., 15 min., 60 min., 4 h and 24 h. This method was replicated three times and the rate of expansion was calculated to know the critical time to tying to regain the shape and size of densified bale.

RESULTS AND DISCUSSIONS

Compaction and baling

The operation was studied to judge the distribution of time required for each activity. For three types of filling, results are shown in Table – 1&2. It was observed that the time consumption was more in loading the straw in the chamber and in tying activity as compared to other activities. Maximum time required was for tying and it ranged from 43-46% of total time. Therefore different methods were considered for reducing tying

Table 1. Time required (seconds) for different activities during the operations of baler in different types of filling (3 – replications)

Activity	Free filling, s		Medium filling, s		Compact filling, s	
	Range	*Avg.	Range	*Avg.	Range	*Avg.
Filling	107-150	134.66	170-210	186.66	280-218	201.33
Compression	93-05	94.33 ^c	96-97	96.33	96-98	97.00
Tying	270-275	272.66	280-290	285	296-310	302.00
Return stroke	94	94	94	94	94	94
Total time, s	516-629	595.65	561-612	661.99	558-71	694.33
Bale Weight, kg	8-9	8.66	13-14	13.66	20.5-21.5	21.00
Bulk density,kg/m ³	75.97- 85.47	82.24	123.46 -132.95	129.73	194.43 -204.18	199.43

Table 2. Percentage time required for each activity

Activity	Free filling	Medium filling	Compact filling
Filling	22.61	28.20	29.00
Compression	15.84	14.55	13.97
Tying	45.77	43.05	43.49
Return stroke	15.78	14.20	13.54
Total time	100.00	100.00	100.00

time. Also, it was difficult to unload the bale from the machine. Due to increase in length of shaft, the compression part could compress the straw around 3-4 cm from both sides and the bale could be taken out easily from the machine door. It was so because of reduction in length of bale.

Tying Methods

Details of comparison are shown in Table-3. Two approaches i.e. U clip welding and m.s. wire were found to be the low cost options (Rs 1.90/bale) followed by U clip (Table 3). This reveals time saving by 75% and economy. On the other side the prefab wire mesh is also less time consuming but it is costly with tying cost of Rs 22/bale. However, the advantage is that it can be reused 8-10 times. This can be

made feasible if the wire mesh is returned to baling unit and reused for tying. After many trials it was found that prefab wire mesh could save about 80 per cent of time that of material tying.

Expansion Characteristics

The average values of total expansion and rate of expansion are shown in Table-4 and 5. Total expansion and also the rate of expansion was maximum in the direction of the compression force. Any increase in moisture content of the straw caused the total expansion and rate of expansion to decrease. The expansion after 24 hours was practically absent. Therefore, expansion measurement was discontinued after 24 h. Table 4 shows that as the moisture content of

Table 3. Comparative details of different tying methods

Tying Technique	Time taken (s)	Quantity used, g	Material cost, Rs/kg	Tying cost of bale, Rs
JuteNylon	280278	198154	35.0075.00	6.9311.55
Ms bindingWires	286	88	22.00	1.93
Prefab wire mesh	73	3.00 X 1.2 m	Rs 30.00/40m	22.5*
U-Clip	142	200	22.00	4.4
MS-wire U-ClipWelding	60	88	22.00	1.93

*Can be reused many times.

Table 4. Expansion (cm) of paddy straw at different moisture content and durations after release of pressure.

Time (min)	Moisture content (%)														
	Lengthwise (L)					Height wise (H)					Width wise (W)				
	10	15	20	25	30	10	15	20	25	30	10	15	20	25	30
0.5	27.0	24.0	22.0	20.0	18.0	8.0	7.0	6.0	6.0	5.0	4.0	4.0	4.0	3.0	3.0
1	36.0	32.0	27.0	24.0	21.0	11.0	9.5	8.5	7.5	6.5	4.0	4.0	4.0	3.0	3.0
5	40.0	36.0	31.0	27.0	24.0	12.5	11.0	10.0	9.0	8.0	6.0	6.0	6.0	5.0	5.0
15	43.0	39.0	33.0	29.0	26.0	14.0	12.5	11.0	10.0	9.0	6.0	6.0	6.0	5.0	5.0
60	45.0	41.0	35.0	31.0	28.0	14.5	13.0	11.5	10.5	9.5	7.0	6.0	6.0	5.0	5.0
240	46.0	42.0	36.0	32.0	29.30	15.0	13.5	12.0	11.0	10.0	8.0	7.0	7.0	6.0	6.0
1440	48.0	44.0	38.0	34.0	31.0	16.0	14.5	13.0	12.0	11.0	10.0	9.0	8.0	7.0	7.0

straw increases the total expansion decreases for any given duration after release of pressure. The trend was same for all the durations and the directions studied in this set of experiments. Indicative pattern is

depicted (Fig. 4) for length, height and width based expansions. Incremental one side rate of expansion of straw bale in different directions/ dimension (Fig.5) reveals sharp decline in rate of expansion with time

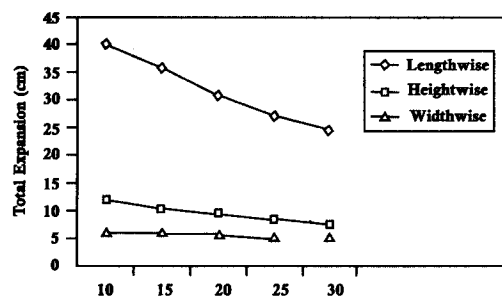

Fig. 4. Total expansion at different moisture content at 5 min.

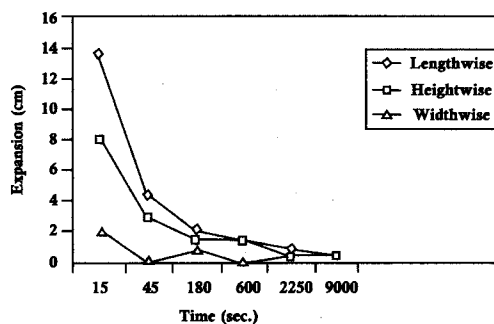

Fig. 5. Incremental expansion of bale at 10% m.c.

www.IndianJournals.com
Not for Commercial Use
Downloaded From IP - 216.73.216.52 on dated 24-May-2026

Table 5. Average rate of one side expansion of paddy straw bale in different directions when baled at different moisture content levels.

Moisture content (%)	Time (s)	length (cm/s)*	height (cm/s)*	width (cm/s)*
10	15	0.450	0.260	0.067
	45	0.150	0.100	0.000
	180	0.008	0.006	0.004
	600	0.003	0.003	0.000
	2250	0.000	0.000	0.000
	14400	0.000	0.000	0.000
	86400	0.000	0.000	0.000
15	15	0.400	0.233	0.067
	45	0.133	0.050	0.000
	180	0.008	0.006	0.004
	600	0.003	0.003	0.000
	2250	0.001	0.000	0.000
	14400	0.000	0.000	0.000
	86400	0.000	0.000	0.000
20	15	0.367	0.20	0.067
	45	0.083	0.083	0.000
	180	0.008	0.003	0.004
	600	0.002	0.002	0.000
	2250	0.000	0.000	0.000
	14400	0.000	0.000	0.000
	86400	0.000	0.000	0.000
25	15	0.333	0.200	0.050
	45	0.067	0.050	0.000
	180	0.006	0.006	0.004
	600	0.002	0.002	0.000
	2250	0.000	0.000	0.000
	14400	0.000	0.000	0.000
	86400	0.000	0.000	0.000
30	15	0.300	0.166	0.050
	45	0.050	0.050	0.000
	180	0.006	0.006	0.002
	600	0.002	0.002	0.000
	2250	0.000	0.000	0.000
	14400	0.000	0.000	0.000
	86400	0.000	0.000	0.000

indicating for the need to tie the bale within 30 s after release of pressure after formation of bale by compression. Table. 5 shows average rate of one side expansion in different directions and depicts that the rate of expansion drastically reduces after 30 seconds of expansion duration and hence the need for tying of bale within 30 s of release of pressure after compaction of straw for bale formation. Rate of expansion indicated that 30 seconds is the critical time for tying and length- wise tying should be attempted first followed by height and width side.

CONCLUSIONS

It can be concluded that:

1. In case of tying, the U-clip welding method was most economical and time saving up to 80 per cent could be achieved with respect to old method of tying (needle and rope). Pre-fab wire mesh is another option, which can be exercised provided availability of the tying system is possible for reuse.
2. The rate of expansion during first 30 seconds is maximum. It decreased rapidly after 5 min and is almost significant after 24 h. Total expansion and rate of expansion is maximum in the direction of compression followed by other two dimensions indicating that the tying should be initiated first on length side followed by height and width.

ACKNOWLEDGEMENTS

The authors duly acknowledge the funding support under NATP for this work. Also, inputs given by SRFs Er. D Kadam, Er. A Parey and Er. R. Sharma are acknowledged.

REFERENCES

- Gupta CP.2000 Forage baling/identification equipment, concept and future. Paper presented at first NATP Workshop of PSR-39 on "Baling, Densification and Storage of Grasses, Fodder and Crop Residues", IGFRI, Jhansi Dec. 16-18, 2000.
- Gupta PD Goyal RK and Chattopadhyay PS. 2000. High-density baling machine for economics transport and storage of grasses and crop residues – a step towards fodders bank: Indian farming, pp. 10-13.
- Gupta PD, Goyal RK, Chttopadhyay PS and Pachuri V.C. 1997-98. Annual report of IGFRI, Jhansi. "Studies on compaction, storage and transport of crop residue and grasses GFRI-NDDB collaborative research project.
- Prakash S and Gupta RK 1986. Annual report, CIAE, AICRP ON PHT presented in 14th Annual Workshop at TNAU, Coimbatore, "Design and development of structure for treatment of Animal feed in bulk" pp. 24-30.
- Dogherty M.J.O. Wheller JA. 1984. Compression of straw to high densities in closed cylindrical dies. Journal of Agric. Engg., Research **29** (1), 61-72.